

Butée à barillet

Document réponse 1 :

Question 1

Repères des pièces

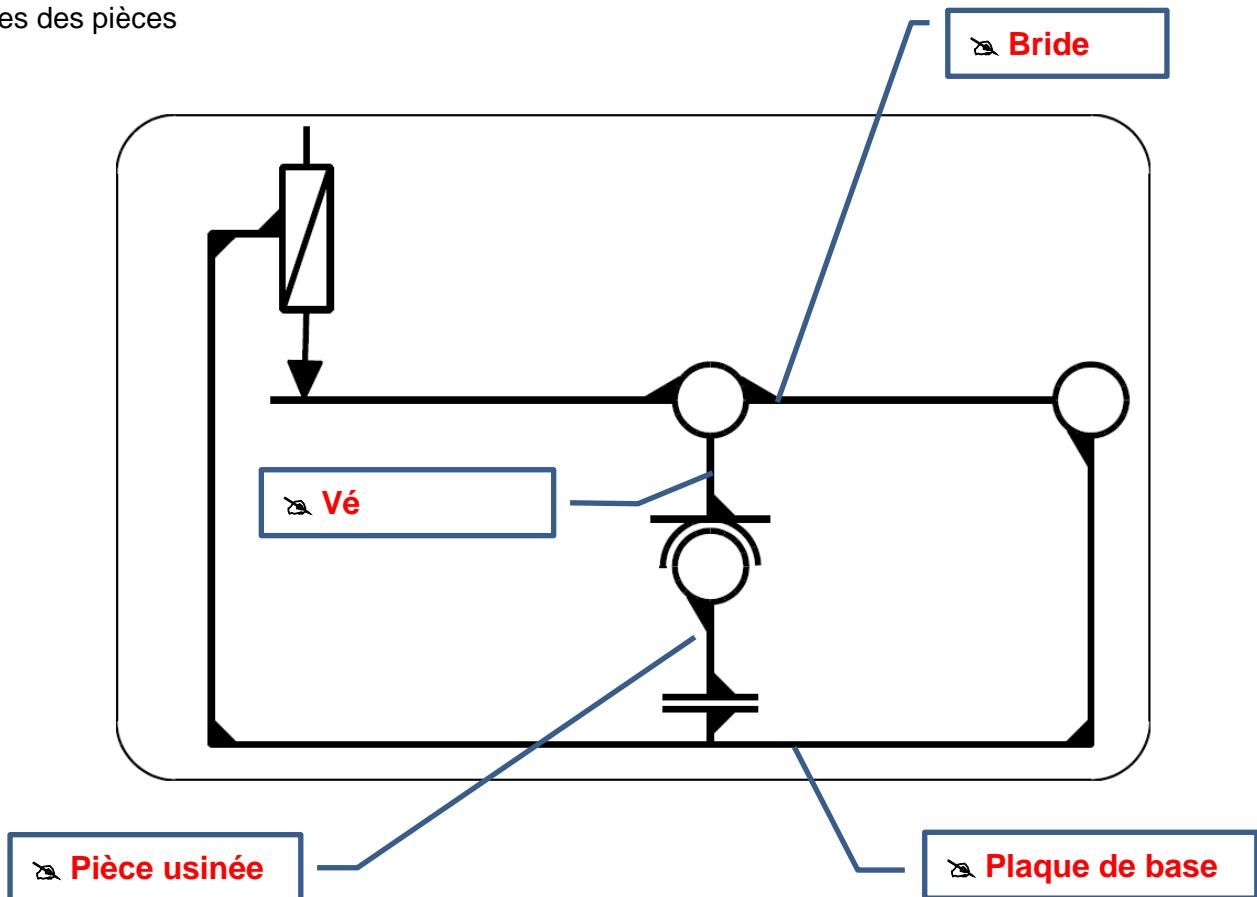

Question 2

Noms des liaisons

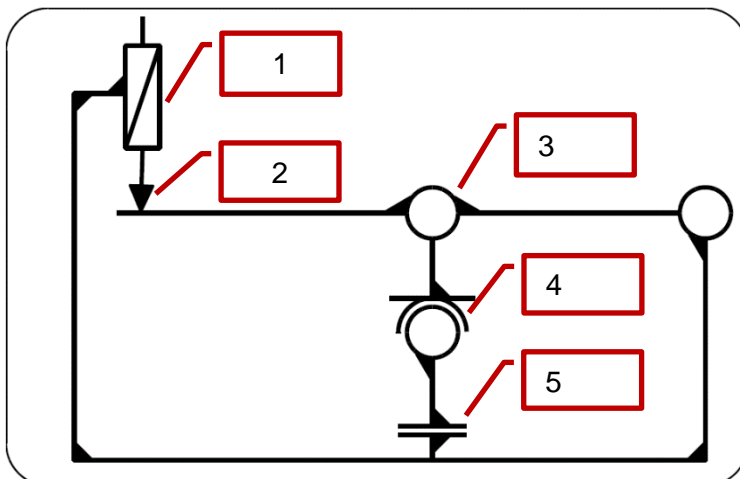

1 : **Liaison hélicoïdale**

2 : **Liaison sphère plan (ou ponctuelle)**

3 : **Liaison pivot**

4 : **Liaison sphère cylindre (ou vé court)**

5 : **liaison appui plan**

H G F E D C B A

8
7
6
5
4
3
2
1

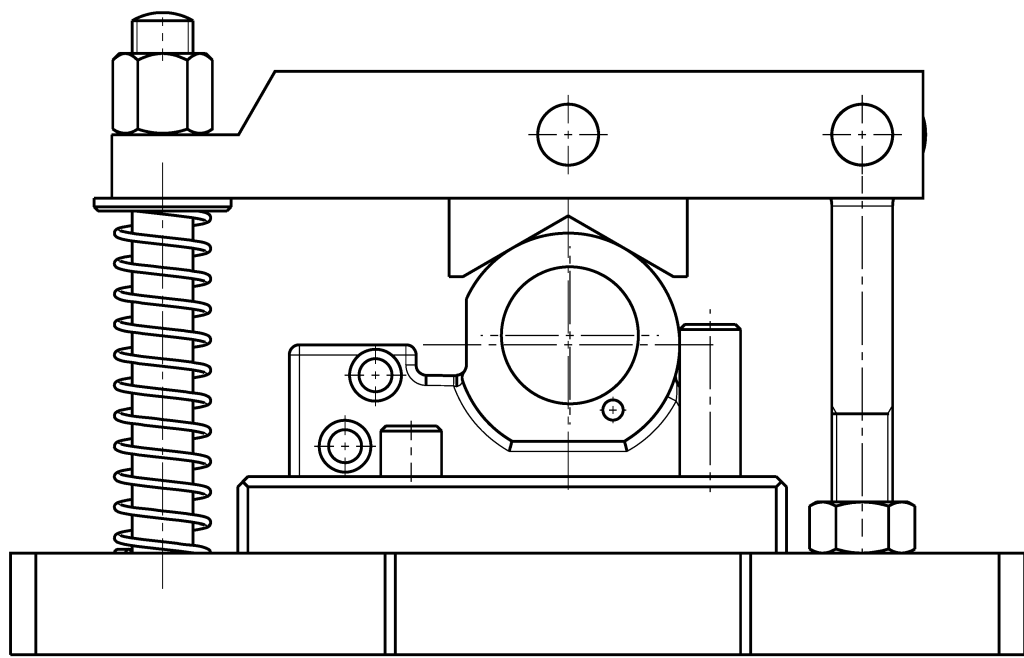

Vue de face
Echelle : 1:1

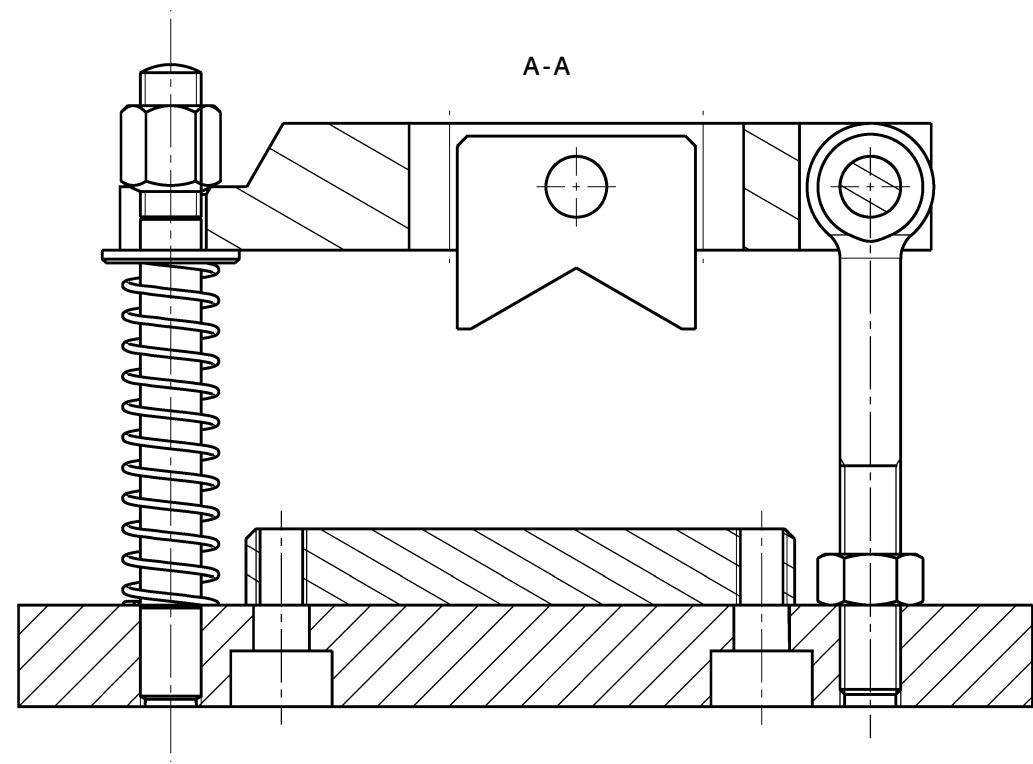

A-A

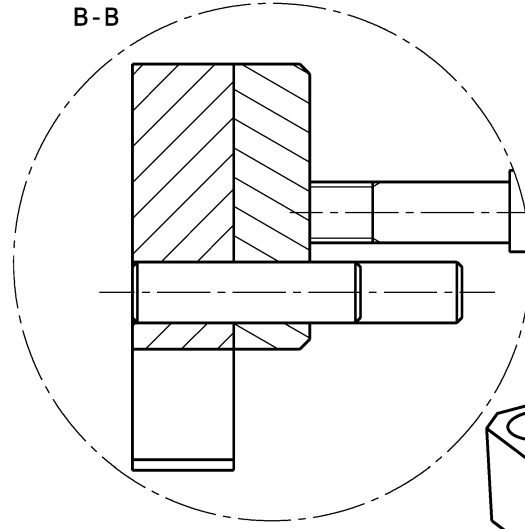
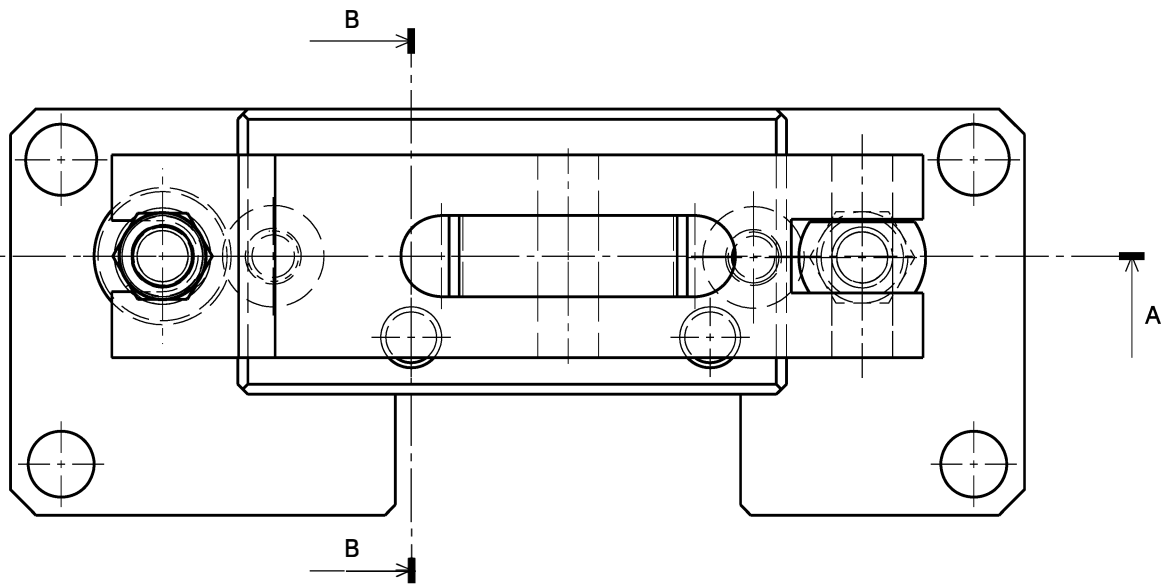

B-B

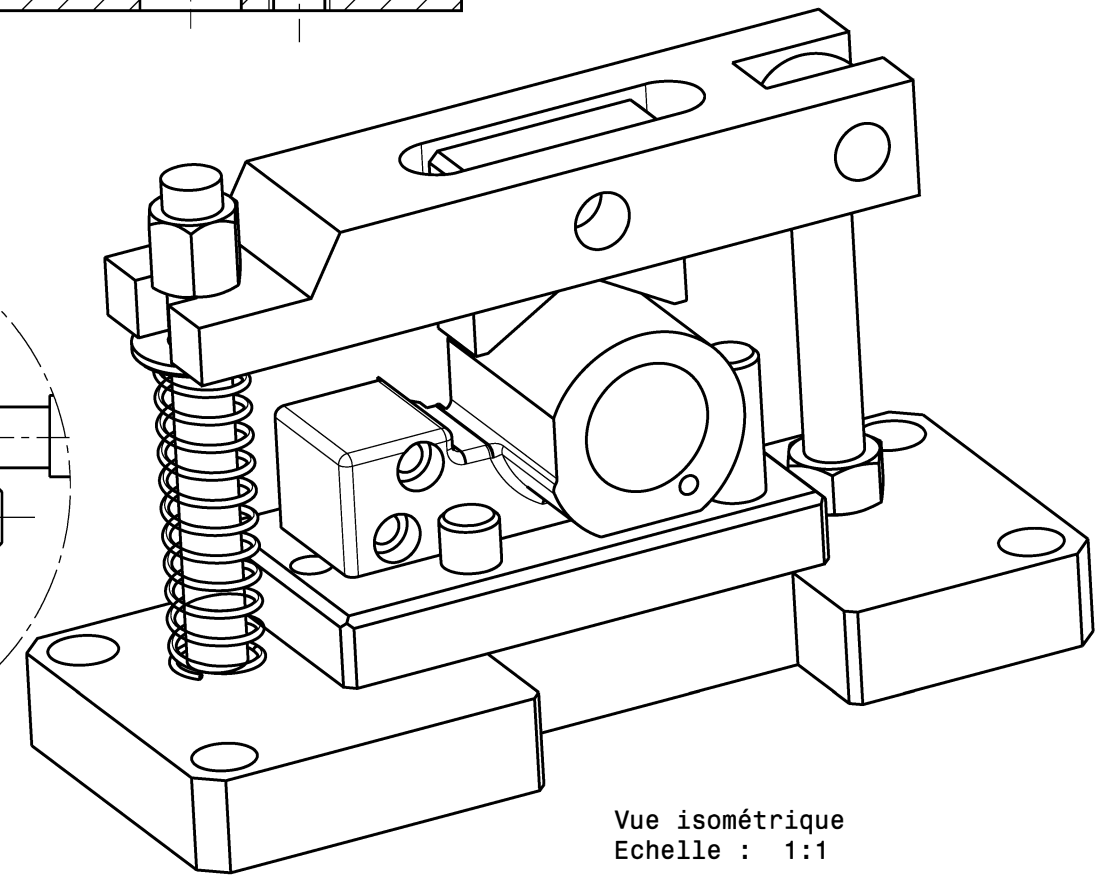

Vue isométrique
Echelle : 1:1

DESIGNED BY: jgb	BARILLET MONTAGE D'USINAGE		I	-
DATE: 30/08/2021			H	-
CHECKED BY: XXX	Lycée Jean Moulin - Béziers		G	-
DATE: XXX			F	-
SIZE: A2		DRAWING NUMBER XXX	E	-
SCALE: 1:1			WEIGHT (kg): XXX	D
		SHEET 1/1	C	-
			B	-
			A	-

This drawing is our property; it can't be reproduced or communicated without our written agreement.

H G B A